

# J5 010V 30W 12V

BL Power

Dimming LED Driver (0-10V)  
30W, Constant Voltage, 12VDC



Featuring smooth 0-10V dimming, the J5 010V drivers are UL Listed, Class 2, and have a universal 100-277VAC input voltage. Available in a range of sizes that can power up to 180W over 3x60W output channels, these constant voltage LED Drivers are enclosed in a low profile housing with integrated wiring compartments, making installation easy.

CLIENT	
PROJECT NAME	
LOCATION	
DATE	

## Product Detail



<b>Electrical</b>	Input Voltage	100-277VAC	
	Input Frequency	47-63 Hz	
	Max Input Current	0.5A	
	Output Voltage	12VDC, Constant Voltage	
	Power	30W	
	Min. Power Draw	3W	
	Dimming	0-10V	
	Min. Dimming Level	0%	
	Max. Output Current	1.25A	
	Connections	16 AWG, Copper Conductors	
<b>Mechanical</b>	Power Factor	0.95 - 0.99	
	Ambient Temperature	-40°F to 140°F (-40°C to 60°C)	
	Max. Case Temperature	140°F (60°C)	
	Circuit	Class 2	
	Housing Construction	Anodized Aluminum	
	Weight	2.1lb (0.95kg)	
	Environmental	IP65	



## Ordering

Product Code	Series	Power	Output	Input Voltage	IP Rating
J510	P	30W	12	UNI	IP65

## Dimensions

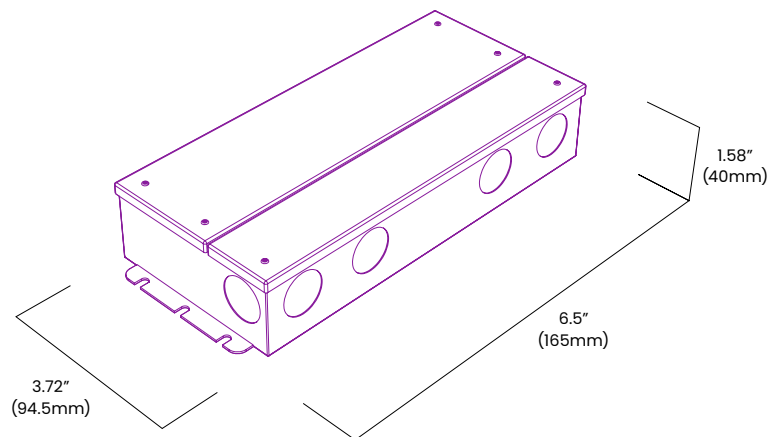

### BL LIGHTING ILLUMINATE EVERYTHING

111 - 8838 Heather St. Vancouver, BC, Canada. V6P 3S8  
P: 1-804-874-4405 E: info@bllighting.com  
Copyright © BL INNOVATIVE LIGHTING. All Rights Reserved.

Solid State Lighting is sensitive to power fluctuations. Surge protection is highly recommended for all LED lighting products and should be on a dedicated circuit to protect against premature failure. Lack of surge protection may void your warranty.

Designed & Assembled in North America.

Specifications subject to change without notice. Please refer to our website at [bllighting.com](http://bllighting.com) for current technical data.

For more information, please download the BL LIGHTING catalog

[bllighting.com](http://bllighting.com)

