

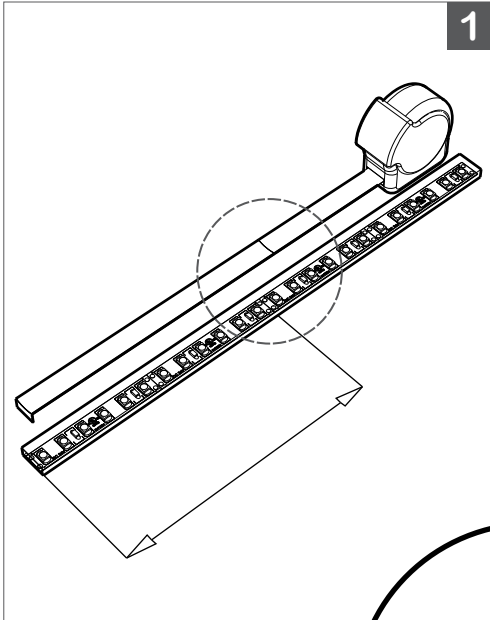

Please note that these instructions are guidelines only and in no way supersede any construction or installation standards. Local building and electrical codes should be consulted before installation.

ATTENTION

- There is potential danger of electrical shock when operating electrical components.
- Make sure power is turned off before installation.
- Allow for heat dissipation and adequate ventilation.



1.

- A. Measure to required length of **LED Tape**.
B. Cut **LED Tape**.

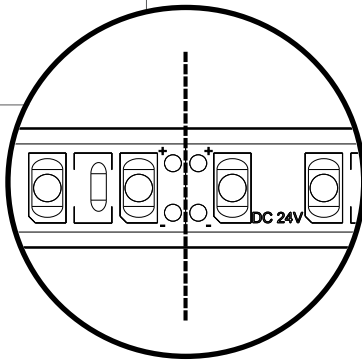

IMPORTANT: Only cut at designated markings on PCB.





Please note that these instructions are guidelines only and in no way supersede any construction or installation standards. Local building and electrical codes should be consulted before installation.

ATTENTION

- There is potential danger of electrical shock when operating electrical components.
- Make sure power is turned off before installation.
- Allow for heat dissipation and adequate ventilation.

2

2.

- A. Insert Red (+) and Black (-) conductors through End Cap.
- B. Solder conductors directly onto PCB at assigned location.

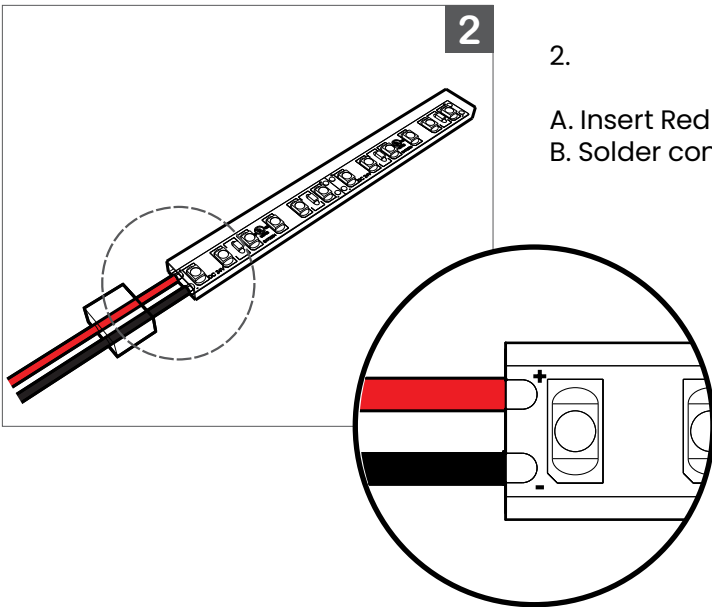

IMPORTANT: Ensure polarity is correct before applying solder.

Confirm and test **LED Tape** connections are working correctly with power supply before proceeding to Step 3.

3

3.

- A. Fill End Caps with RTV sealant. Install onto **LED Tape**.
- B. Allow sealant to cure (24 hours) before installation.

