

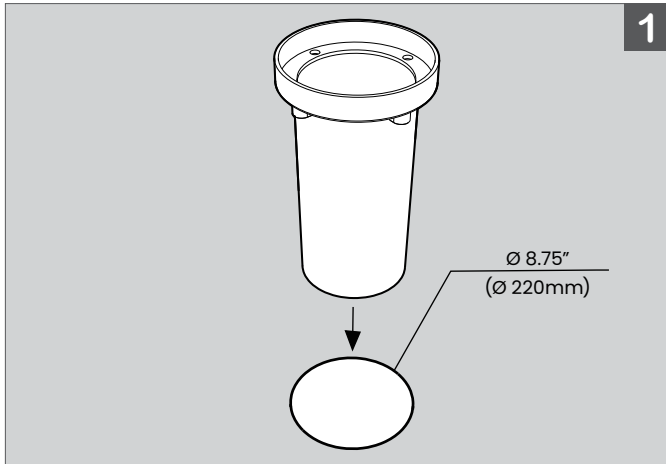

Please note that these instructions are guidelines only and in no way supersede any construction or installation standards. Local building and electrical codes should be consulted before installation.

**ATTENTION**

- There is potential danger of electrical shock when operating electrical components.
- Make sure power is turned off before installation.
- Allow for heat dissipation and adequate ventilation.



1.

Create hole for recessing **DS250** with a 8.75" (220mm) OD. The recessed depth must align **DR250** flange flush to ground level.

**IMPORTANT:** Ensure proper drainage has been included before proceeding.

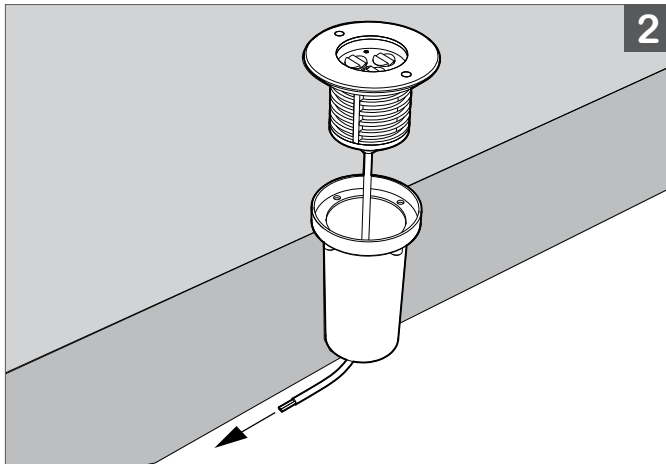

2.

Install boot and run wiring.

**TIP:** Listed flexible conduit is recommended for in and out connections so to ease fixture position and adjustment during installation.



3

3.

Insert luminaire into boot and secure with provided screws.

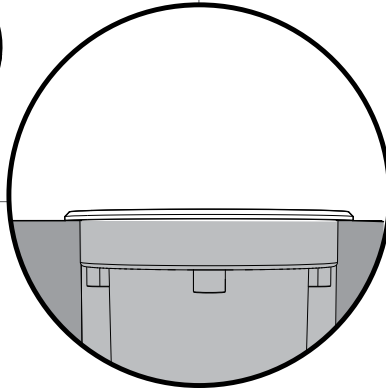
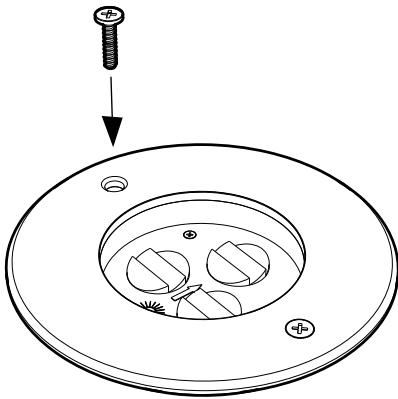

**IMPORTANT:** The luminaire must be level with ground to prevent water leak.  
Seal trim of luminaire with marine grade silicone.

