

*All devices in a DMX512 system must be connected in a "daisy chain" fashion.

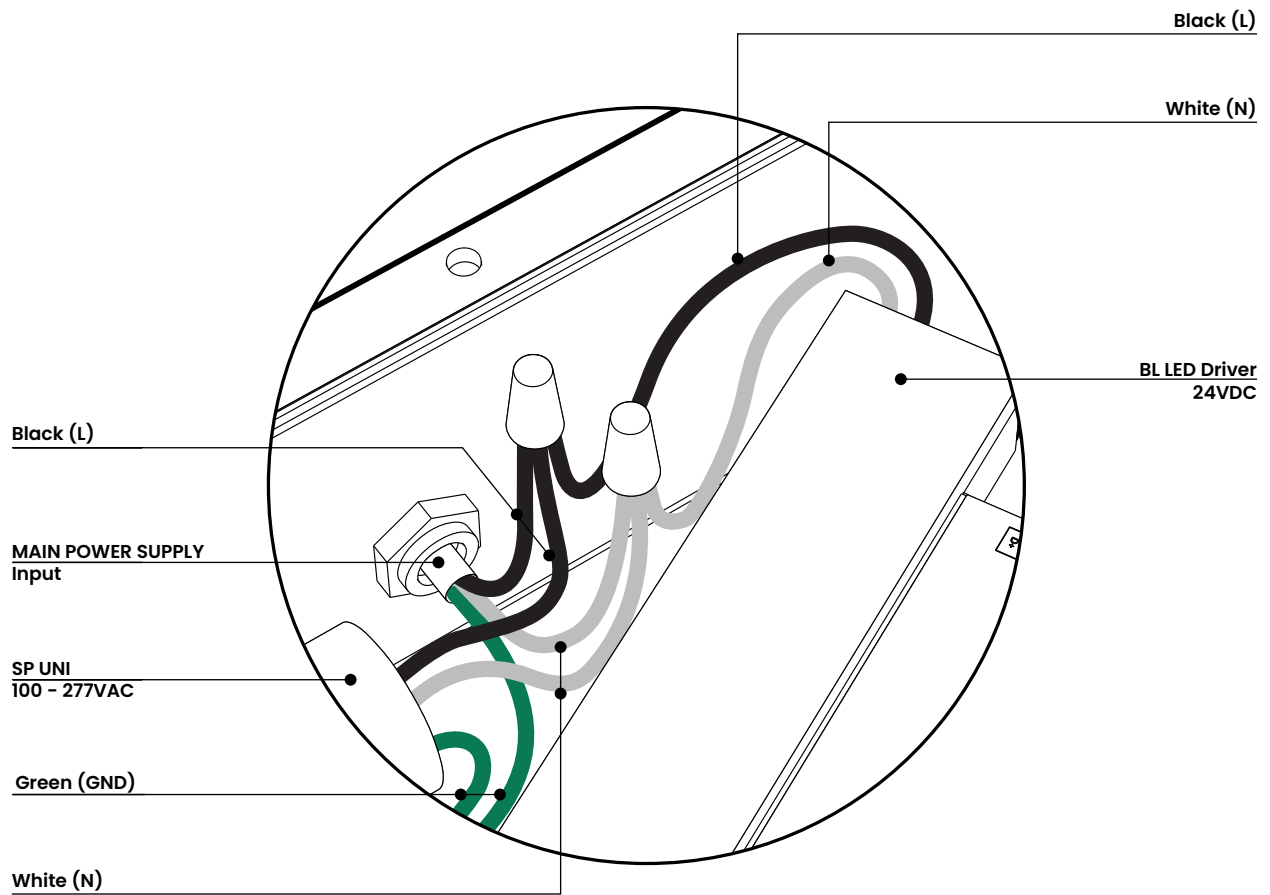

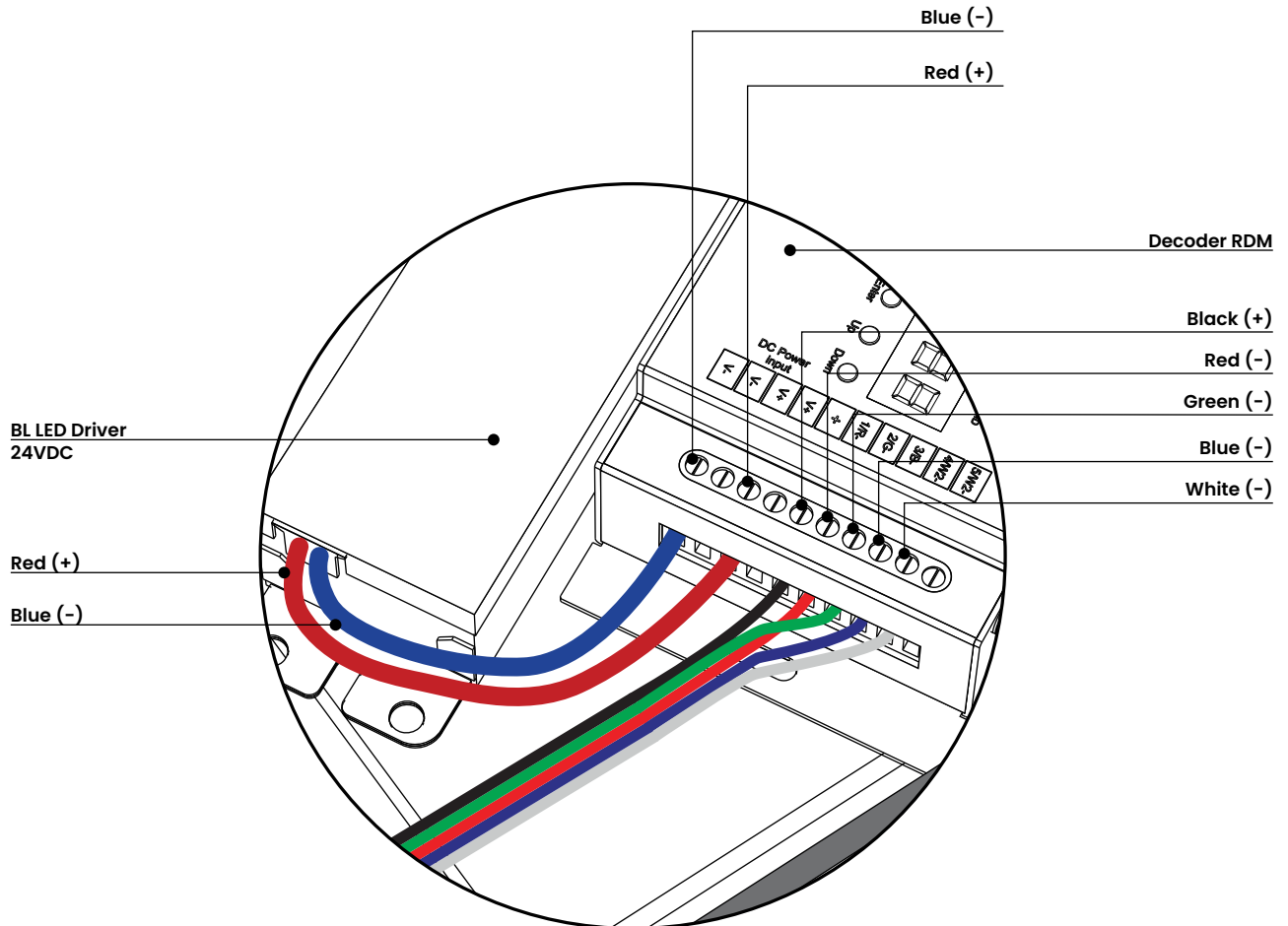

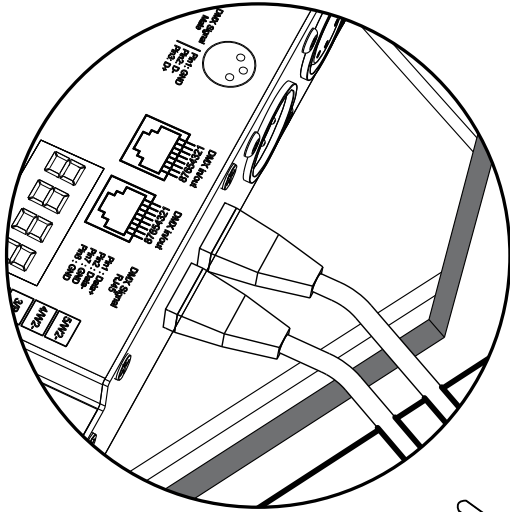



RJ45 Cable DMX IN
From Master Controller

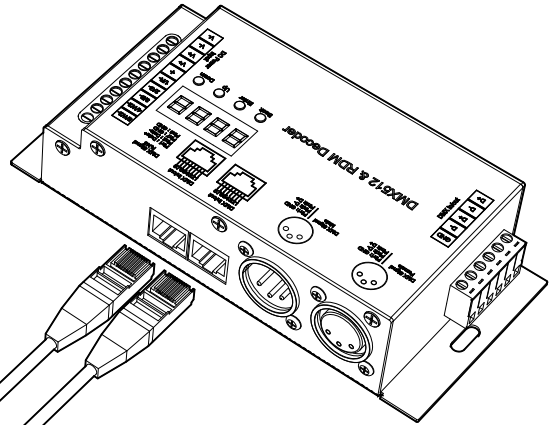

RJ45 Cable DMX OUT
To Next Decoder RDM

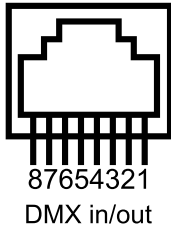

- Pin1 : Data+
- Pin2 : Data-
- Pin7 : GND
- Pin8 : GND

*All devices in a DMX512 system must be connected in a "daisy chain" fashion.



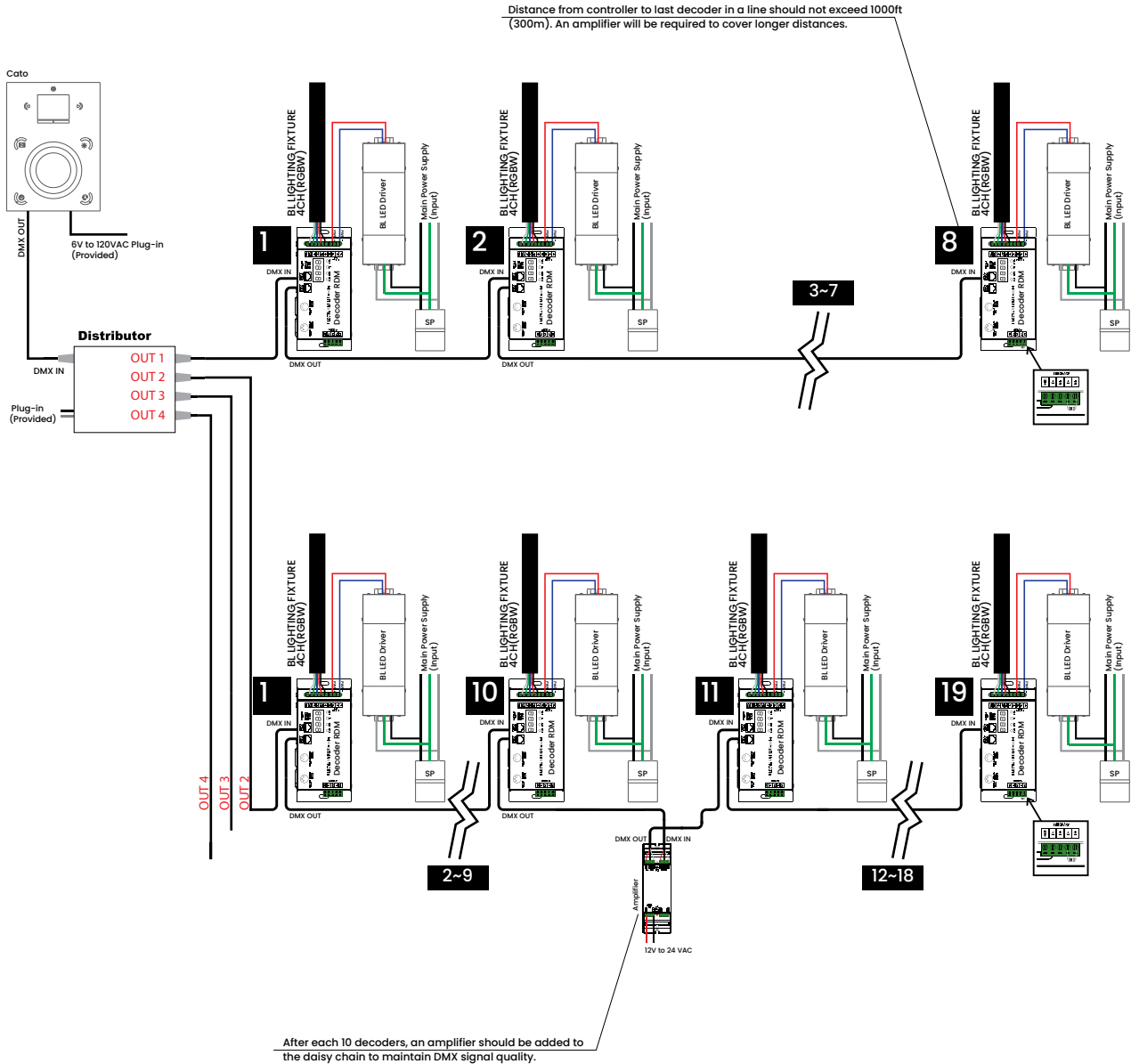

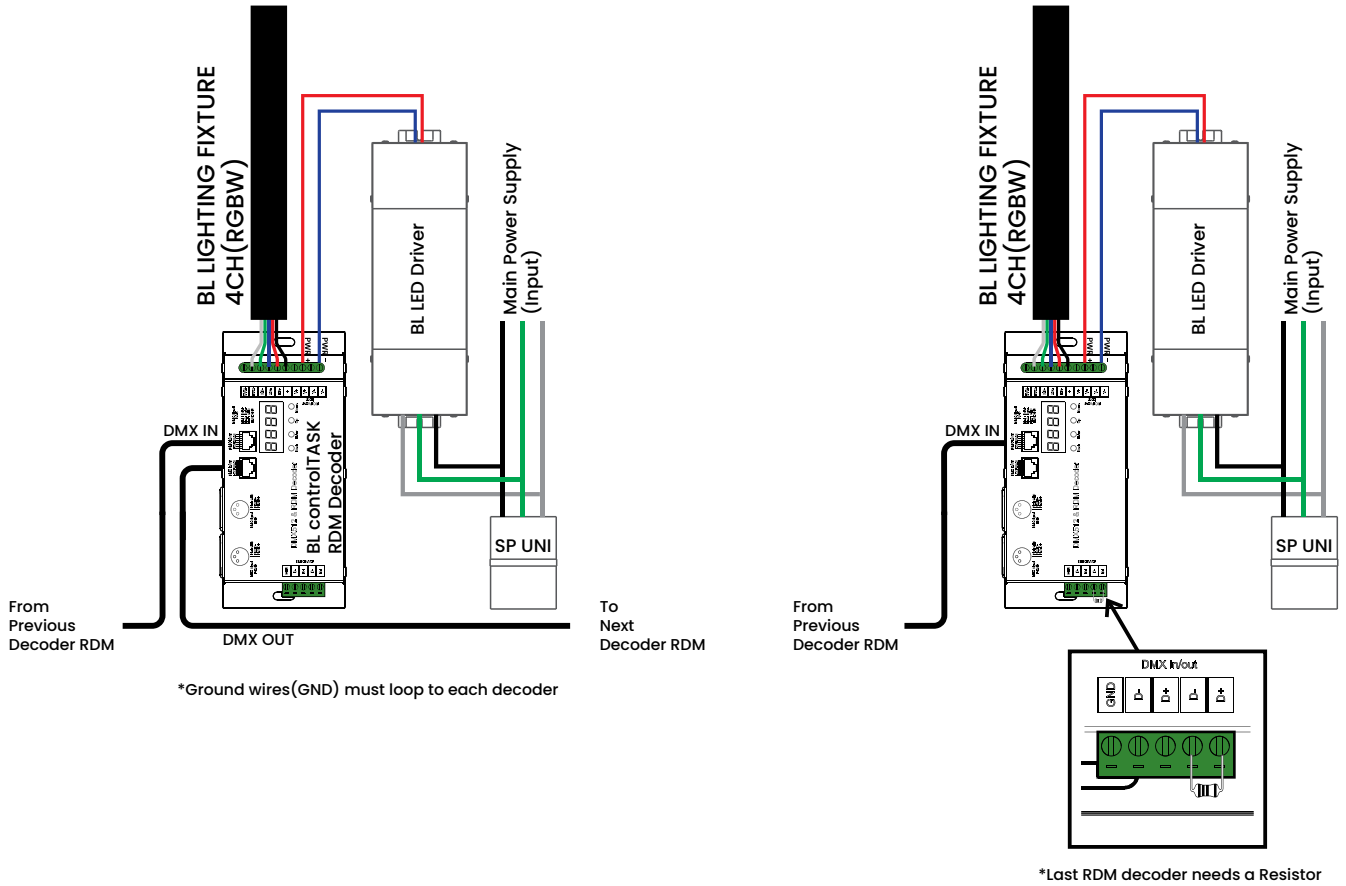

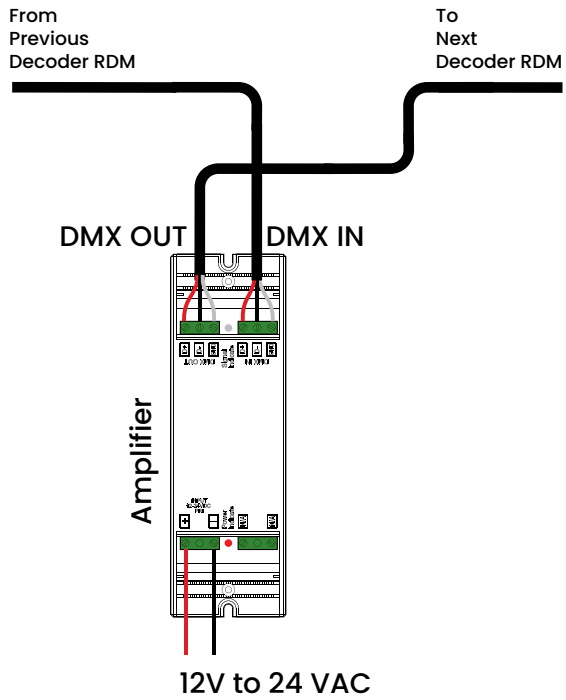

After each 10 decoders, an amplifier should be added to the daisy chain to maintain DMX signal quality.

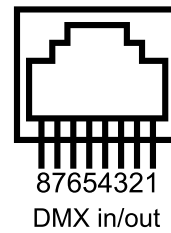
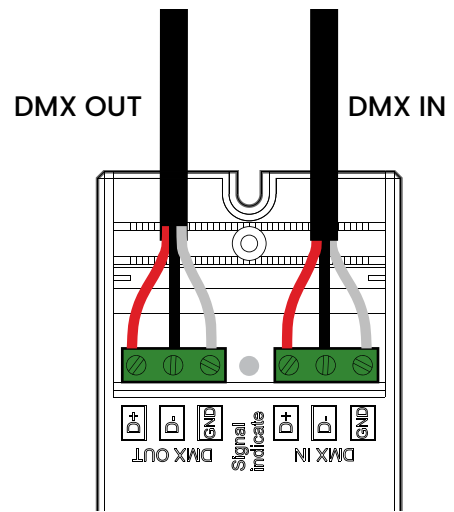

Pin1 : Data+
Pin2 : Data-
Pin7 : GND
Pin8 : GND

