

\*All devices in a DMX512 system must be connected in a "daisy chain" fashion.

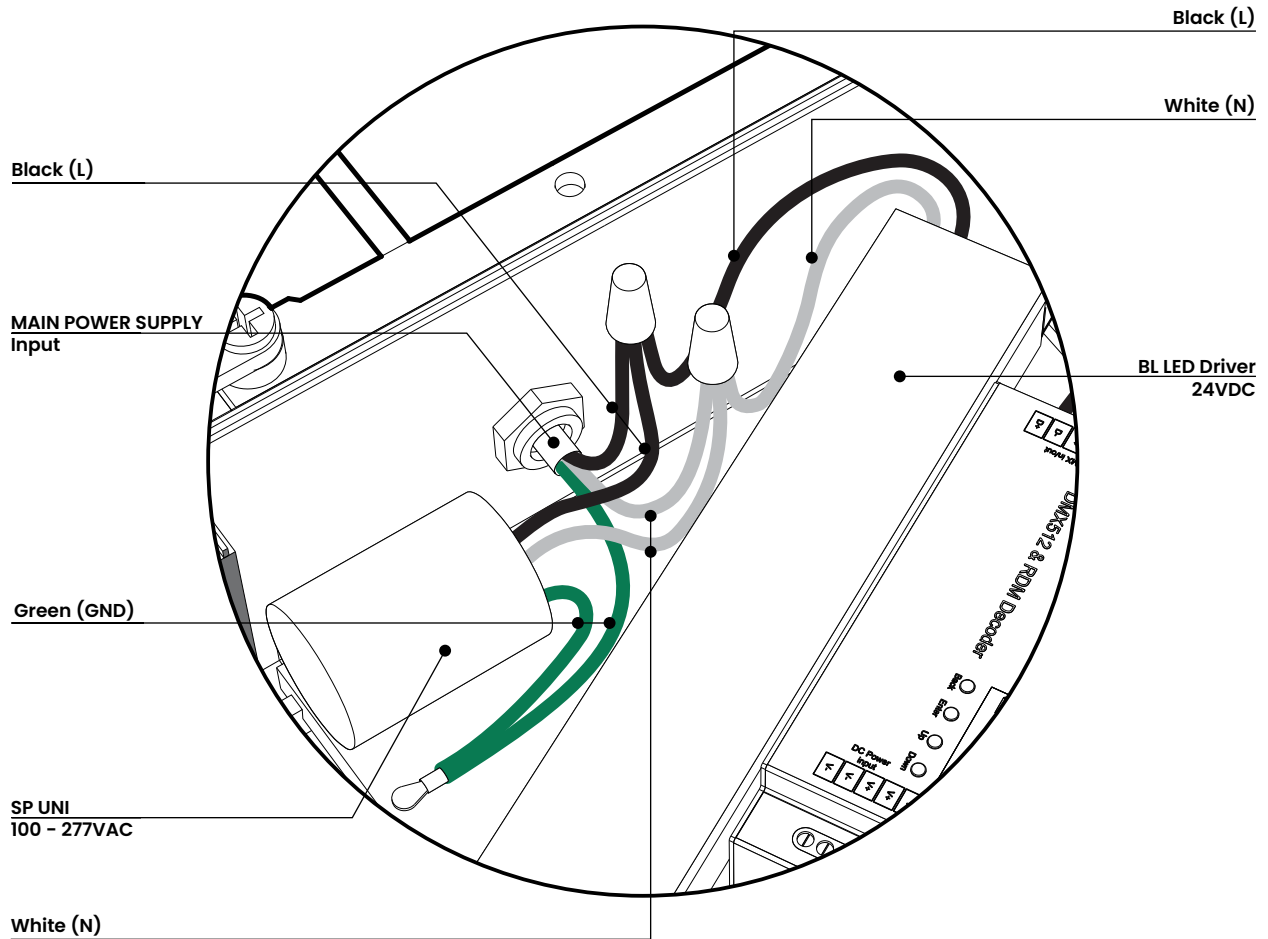

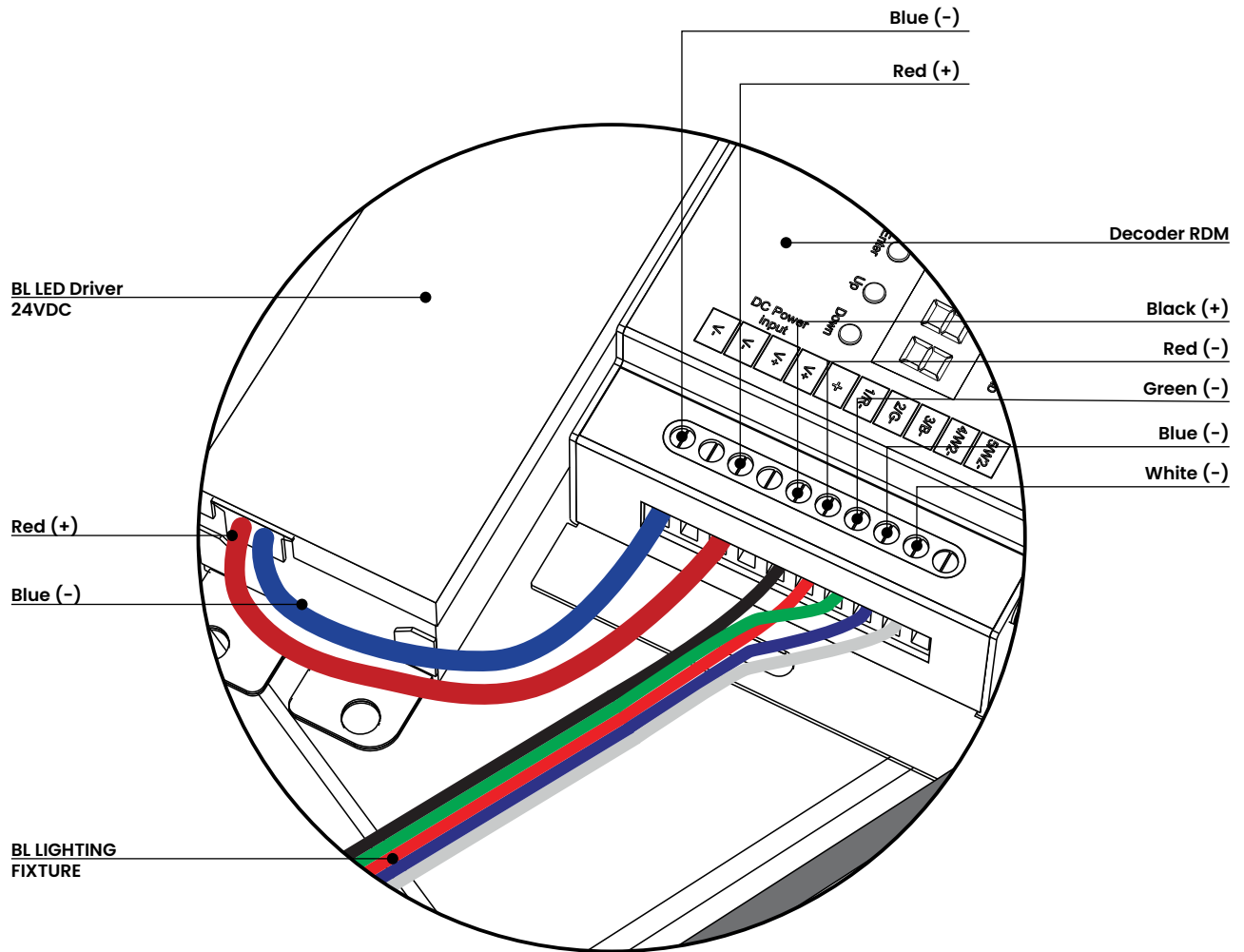

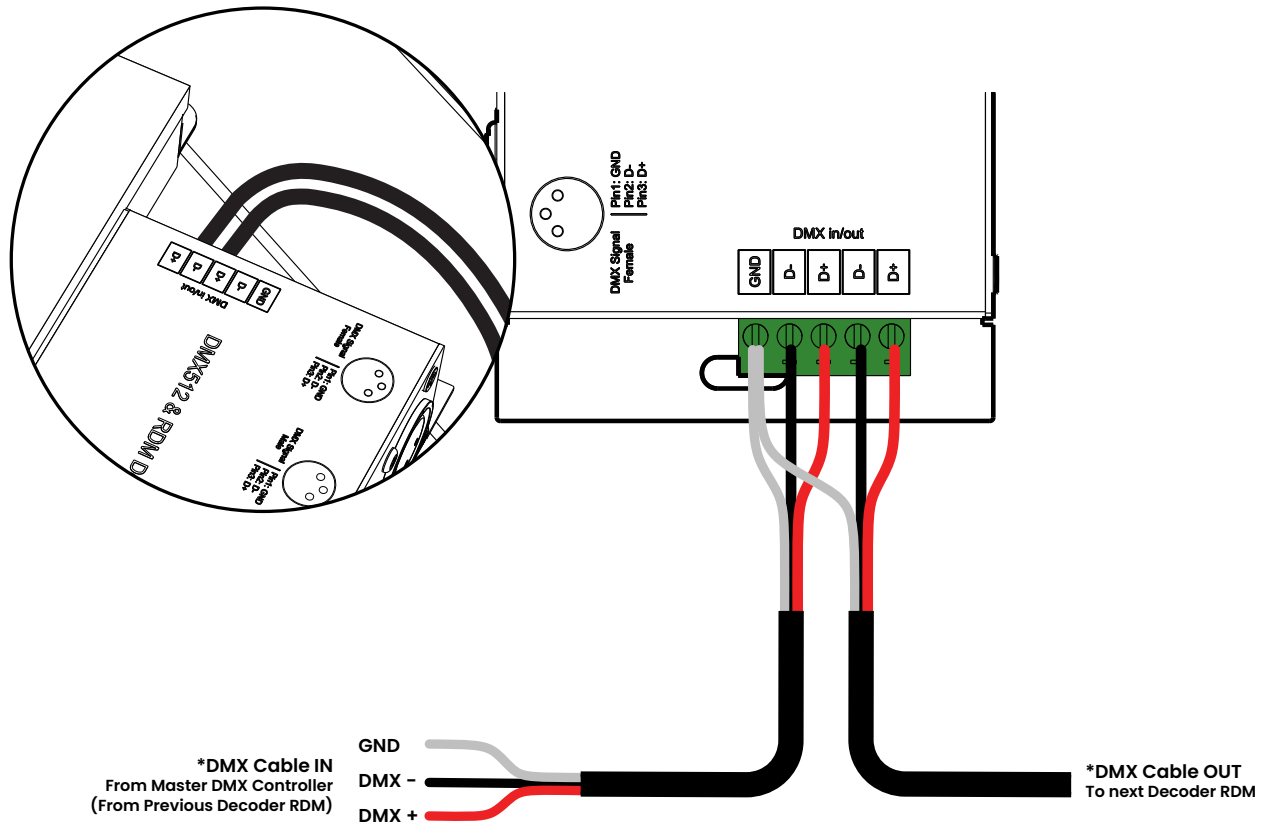



\*All devices in a DMX512 system must be connected in a "daisy chain" fashion.



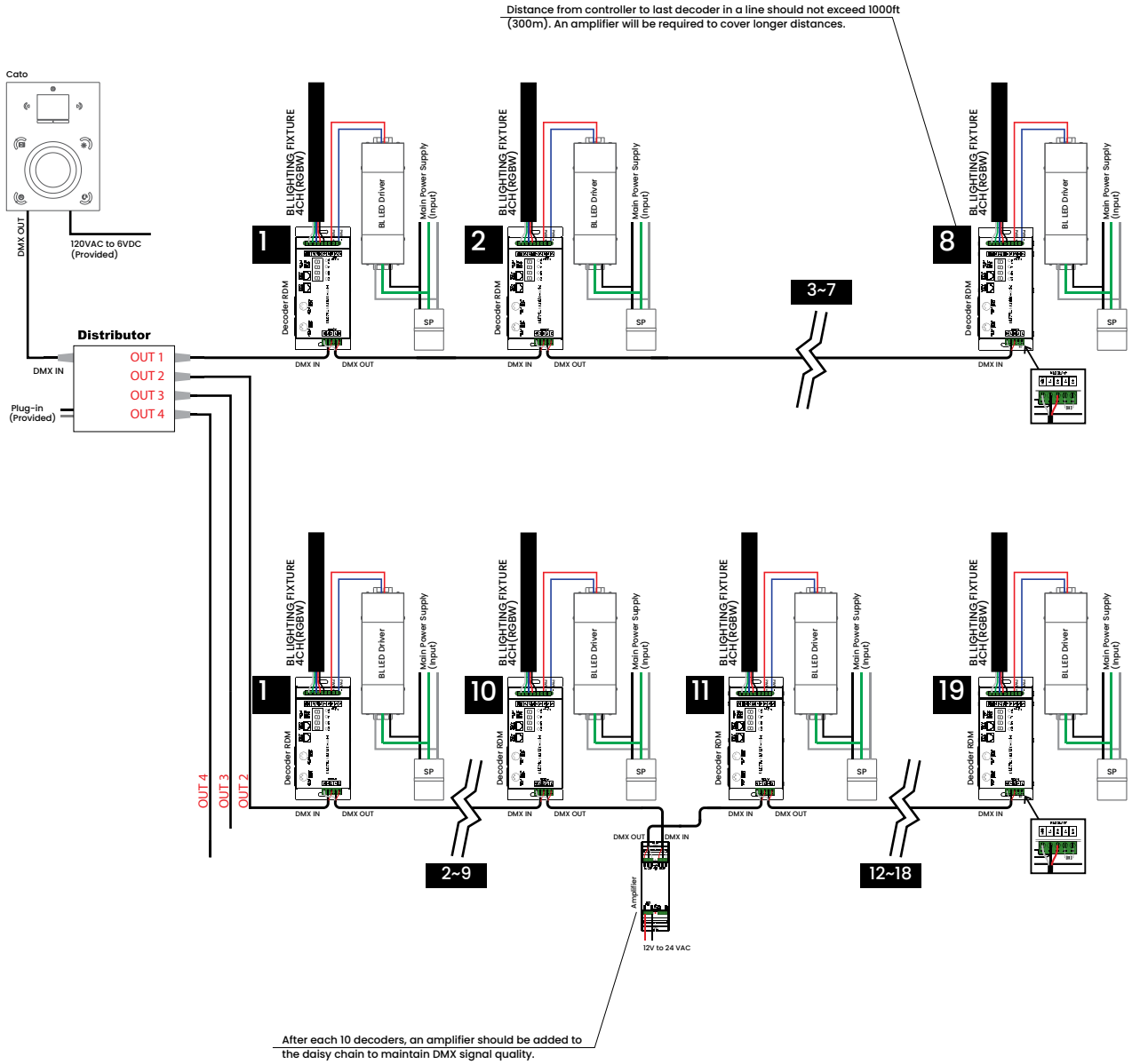

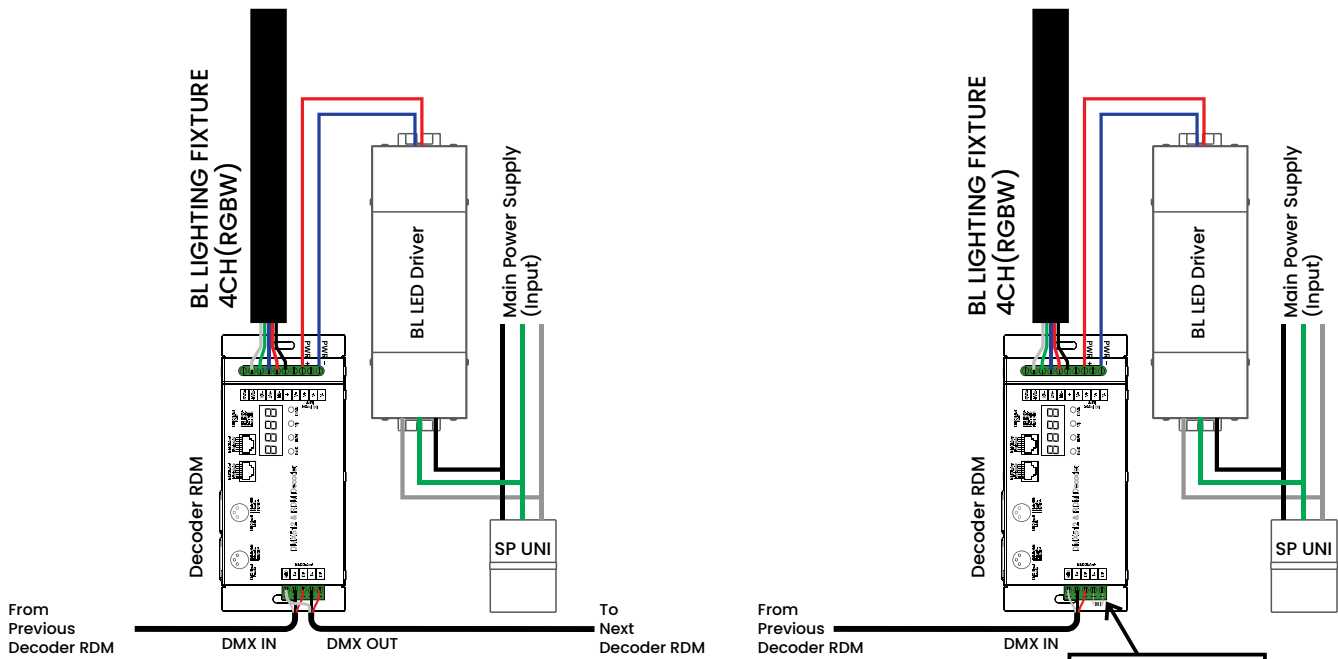

\*Ground wires(GND) must loop to each decoder

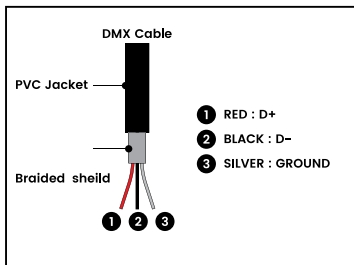

\*Last RDM decoder needs a Resistor



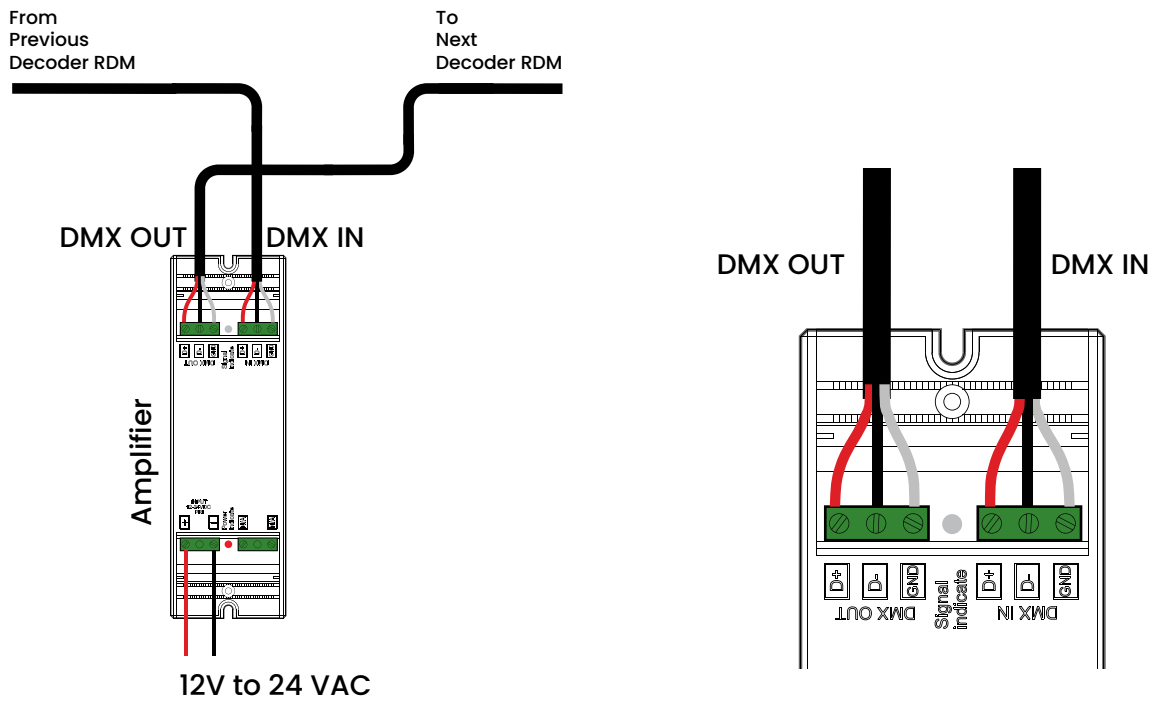

After each 10 decoders, an amplifier should be added to the daisy chain to maintain DMX signal quality.

