



Please note that these instructions are guidelines only and in no way supersede any construction or installation standards. Local building and electrical codes should be consulted before installation.

### ATTENTION

- There is potential danger of electrical shock when operating electrical components.
- Make sure power is turned off before installation.
- Allow for heat dissipation and adequate ventilation.

## Design Considerations

The surrounding environment will have a dramatic effect on the apparent brightness of illuminated fiber. Expectations of performance must be accurately gauged to achieve satisfactory results. Certain colors of the spectrum will appear different, for instance, yellow will appear much brighter than red.

Do not submerge the ends of fiber to any liquid, as it may migrate between the cladding and core of the fiber, causing damage over time. It is recommended to use End Caps and epoxy, or dedicated End Fixtures at the fiber tips for protection and to prevent water ingress in exposed environments.

To prevent water from being wicked along the length and back to the BL Fibersource illuminator, the light sources should be placed at a higher level than the incoming fiber, and the optical fiber can also be looped vertically (a drip loop) before terminating at the illuminator.

## UV Protection

**WARNING:** Do not install fiber optics without protection from UV light.

UV rays will degrade the fiber and seriously affect performance. Fiber ends exposed to UV also must be protected. Indoor installations where fiber optics is subjected to UV from skylights, windows, or lighting that emits UV (for example: some fluorescent lighting) must be protected as well.

Use UV blocking cover (tubing or tracking type). Allow space for expansion and contraction on the corners.

Loss of light transmission and possible damage may result from stresses applied during the natural lengthening and shortening of the fiber as it is heated and cooled.

Starfield Systems will require UV protection when installed outdoors by using UV protective epoxy.



**Attention**

- There is potential danger of electrical shock when operating electrical components. Make sure power is turned off before installation.
- Do not install illuminators in a sealed environment – allow for heat dissipation and adequate ventilation.
- When installing fiber, care should be taken not to scratch or mar the surface.
- Do not bend the fiber at sharp angles. A “hot spot” will develop at point of sharp bends and reduce light transmission along the length.

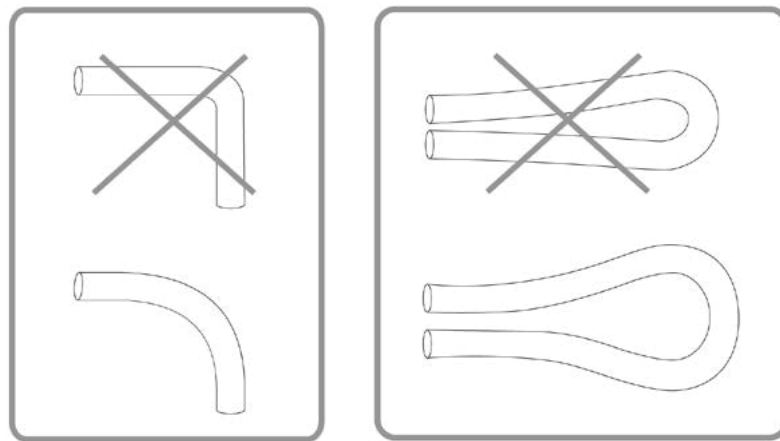

**Cutting Fiber Optics**

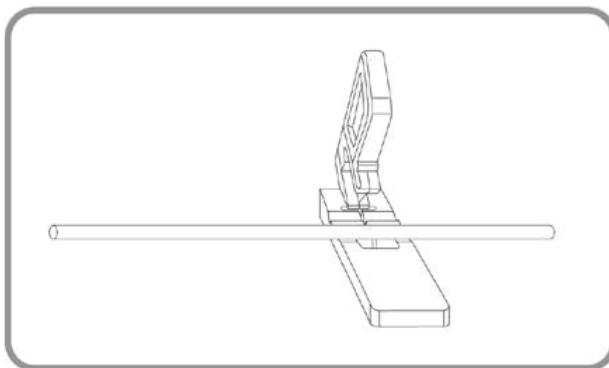

Fiber should be cut at 90° angle with a fiber cutter and with a sharp blade. A clean, clear cut will give maximum performance, whereas a cut with occlusions will result in light loss.

It is recommended to use a BL Fiberoptic Cutting Tool for best results.



### Attaching Fiber Optics into BL Fibersource Aperture



If lighting multiple fiber strands, tape the fibers tightly together using heat resistant tape.

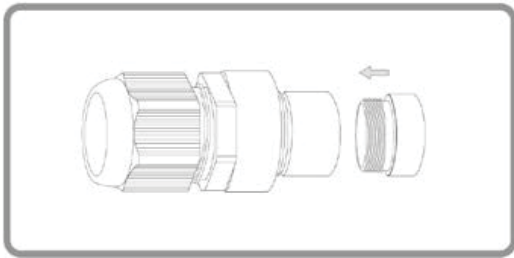

If applicable, connect fiber fitting to strain relief or bushing. Fiber fitting aligns fiber strands to the centre axis of light for maximum light acceptance.

1. Insert fiber into bushing. Make sure fiber is flush with the back of fitting.
2. Do not push fiber strands past the end as they may hinder color/twinkle wheel from rotating and may burn out the motor.
  - Do not push fiber strands out past the end of the bushing or strain relief, to ensure appropriate physical distancing from the internal components.
  - The illuminator should be focused on the ends of the fiber in a manner that presents uniform illumination.
  - Fiber installed at an angle from the centre line will not transmit as much light as fiber that is properly aligned.

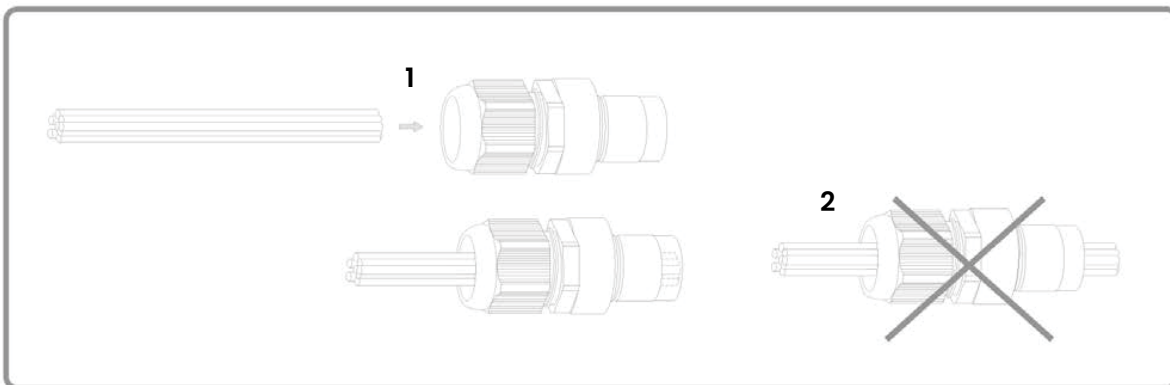

3. Insert fiber adapter into to the fiber port of the BL Fibersource illuminator.
4. Secure fiber adapter with screw.

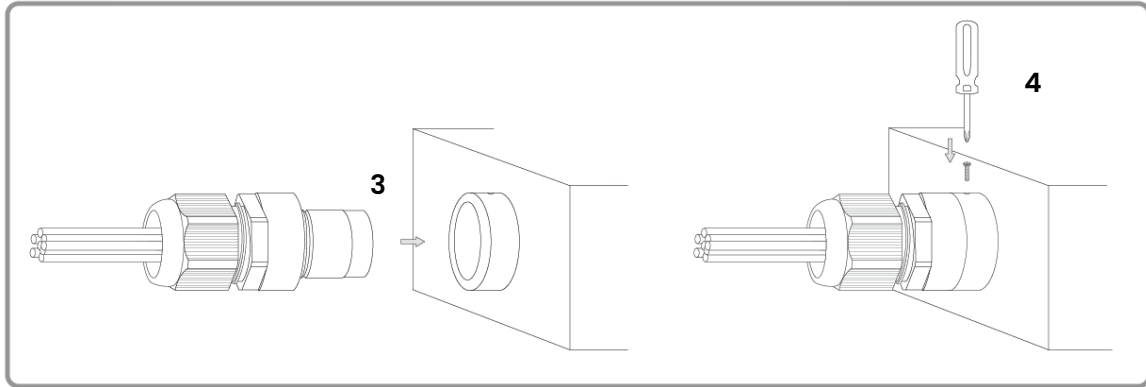

The fiber should lead from the illuminator in a straight line for a few feet before bending. Do not immediately bend the fiber.

**TIP:** Bend fiber into a service loop to provide slack for adjustments and maintenance, as well as to prevent water from migrating back to the BL Fibersource illuminator.

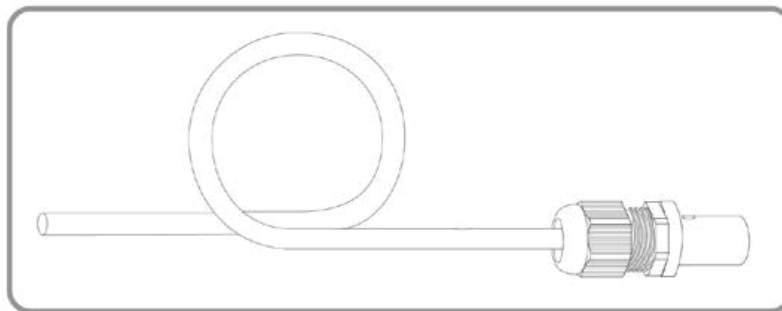

## Mounting

Snap In Mounting Channel is recommended for straight runs of Fiber.

Surface Mounting Clips are recommended for curved installations.

