



## INSTALLATION MANUAL

# Aqua Starfield

BL Fiberoptic

Over Pool Edge

Solid State Lighting is sensitive to power fluctuations  
Surge protection is highly recommended for all LED lighting products and should  
be on a designated circuit to protect against premature failure  
Lack of surge protection may void your warranty

Specifications subject to change without notice.  
Please refer to our website at [bllighting.com](http://bllighting.com) for current technical data.

**BL LIGHTING**  
ILLUMINATE EVERYTHING

111 - 8838 Heather St. Vancouver, BC, Canada. V6P 3S8  
P: 1-604-874-4405 E: [info@bllighting.com](mailto:info@bllighting.com)  
Copyright © BL INNOVATIVE LIGHTING. All Rights Reserved

[bllighting.com](http://bllighting.com)

For pools without perimeter overflow, the easiest method of distributing fibers over the pool floor is to bring the fibers into the pool basin over one side of the pool wall. For pools with perimeter overflow, or any feature that would prevent using the pool wall to lower the fibers onto the pool floor, it's recommended to bring the fibers into the pool basin through a PVC pipe or tube next to the floor and through a trap box to prevent water leakage. (See Aqua Starfield Installation Manual – Below Waterline Installation)

**Design & Installation Tips:**

Aqua Starfield allows you to create the illusion of a starry sky in the pool basin, where the user may immerse themselves in their surroundings to enjoy a rare experience of the weightlessness of a walk in outer space, with a starry sky above and another below. Just what constitutes the appearance of a starry sky effect is subjective, and understanding the design intent, budget and site features is important to choose the correct scale and scope of work, from a few understated and elegant points to enchant and enhance the pool environment, to a full recreation of constellations and any desired starry sky view, creating a dramatic and impressive effect.

Just as the visibility of stars in the night sky is relative to the proximity of light from cities, in a starfield pool, as ambient light levels increase, so too must the intensity and quantity of star points to retain visual impact. Small pools, or those whose extension cannot be taken visually as a whole from any given point will required greater star point densities. Large expanses of water in swimming pools, lakes or water parks need fewer stars, as the distance concentrates the star points visually.

Point density	
Size of water surface (M <sup>2</sup> )	Recommended point density
Under 10	10 to 15
From 10 to 20	6 to 12
From 20 to 50	5 to 10
From 50 to 100	4 to 8
From 100 to 200	3 to 5
Over 200	2 to 4

A real starry sky has a random distribution of stars, with empty areas and others well populated. We recommend distributing the fibers randomly, keeping the points a minimum of 7.87”(200mm) away from vertical walls to prevent reflections, and placing the larger points near the center, or in desired focal areas. For balance, star points should be different sizes and a good rule of thumb is to use 85% of 1mm, 10% are 1.5mm and the balance to consist of 2mm fibers, and clients may elect to use a single 3mm fiber to represent Sirius. Each fiber diameter carries twice as much light as the inferior size, as fibers carry light as a function of their surface. Thus, a 1.5mm fiber is twice as bright as a 1mm fiber, while a 2mm fiber has four times the brightness of a 1mm fiber. A 3mm fiber is 10x brighter than 1mm. Upon request, BL Lighting can supply systems with 1:1 templates for starry sky features such as constellations, shooting stars, comets, nebulas or Zodiac signs.

Illuminators should be placed as close as possible to the pool edge, for practical and budgetary reasons. Longer distances from the illuminator to the star points increases the overall footage of fiber required, adding to the overall cost of materials. Shorter lengths are easier to handle and install on site. For example, with 300 star points, the difference from approximately 16ft(5m) to 32ft(10m) represents 5000ft(1500m) of excess fiber length! Illuminators are recommended to be concealed in a dedicated electrical room, landscape feature, burial box, etc. The illuminator enclosure must be well-ventilated and allow for a minimum of 8" (0.2M) of clearance around each BL Fibersource illuminator. Consult your local electrical code for specific requirements on installation and placement of illuminators in the pool area.

In addition to fiber, illuminators, and fiber supports, perhaps the most critical aspect of a Aqua Starfield is the installation, where care, craftsmanship, and fine attention to details are crucial to the success of the project.

**Phases:**

1. Fiber ingress
2. Floor marking
3. Setting Fiber supports
4. Fiber installation
5. Leveling layer
6. Tiling and grouting
7. Trimming
8. Commissioning

**Schedule**

Phase	Tools and materials	Personnel	Hours	Curing time
Fiber ingress	Must be executed and dry before the Aqua Starfield installation			
Floor marking	Construction Marking Spray Paint	1	1h/100pt	-
Support setting	Multi-Purpose 2 Part Epoxy Adhesive SIKA Power-1511or similar	1	2h/100pt	24h
Fiber installation	Adhesive Fischer MS Ultra Tack or similar. Sundry cable ties. Cutters	2	5h/100pt	-
Leveling layer	By others			
Tiling & Grouting	By others			
Trimming	Flat electronic cutters, polishing bob and polishing compound Menzerna B4F or similar	1	2h/100pt	
Commissioning	Sundry cable ties to tidy fiber bundle connection	1	2h	

## 1. Fiber ingress

### 1-A Tubes and conduits

A PVC plumbing pipe or tube of the suggested diameter (see tube diameters and capacities below) should be laid from the illuminator location to the point of ingress on the uppermost edge of the pool's basin. Alternatively, corrugated conduits of similar internal diameters may be used.

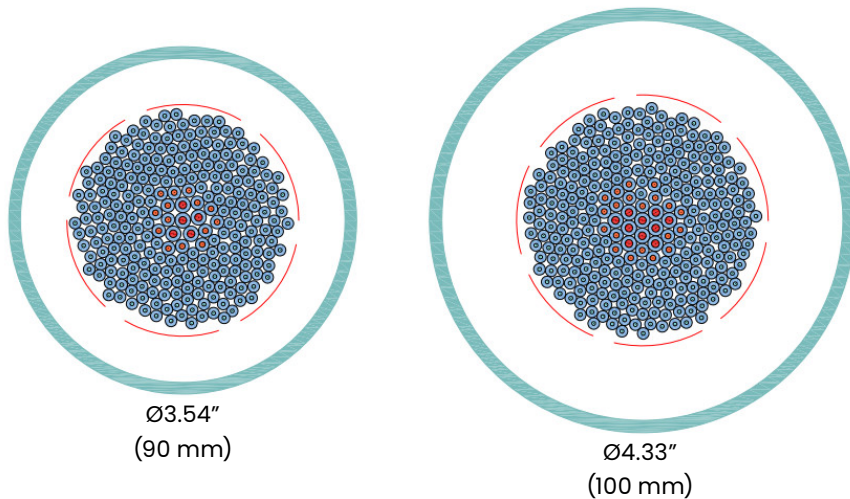
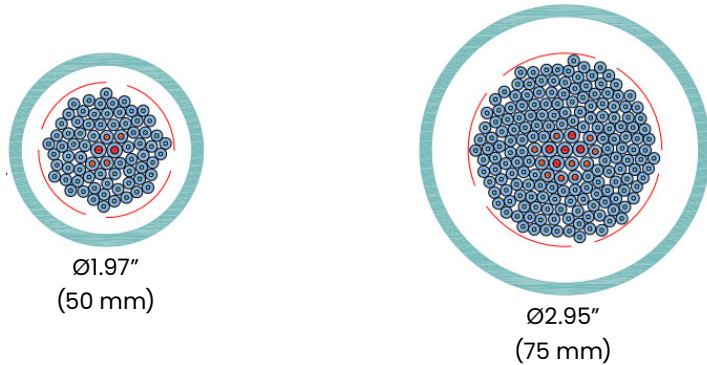

Tube parameters					
Tube type	External ØInch (mm)	Internal ØInch (mm)	Fiber capacity	Fiber mix	Estimated bundle ØInch (mm)
PVC PIPE	1.97" (50mm)	1.73" (44mm)	75	69-4-2	1.38-1.57" (35-40mm)
PVC PIPE	2.95"(75mm)	2.72" (69mm)	185	170-10-5	1.97-2.36" (50-60mm)
PVC PIPE	3.54"(90mm)	3.31" (84mm)	260	240-14-6	2.36-2.76" (60-70mm)
PVC PIPE	4.33"(110mm)	4.07" (103.4mm)	300	270-20-10	2.56-2.95" (65-75mm)

The tube fiber capacities have been calculated for ease of installation with ample margins to avoid congestion. The bundle diameters are estimated. If the tubes cannot follow a straight line from the illuminator location to the pool's basin, we don't recommend 90° bends. Trace the directional changes with 45° bends. If using corrugated tubes, the bends should be gentle, never forced.





### 1-B Wall vertical housing

At the fiber ingress point to the pool basin, prepare a housing or recess in the vertical pool wall for the fibers to be accommodated, built to a minimum depth of 1.97" (50mm) and a width of 19.67" (500mm) for every 300 fibers.

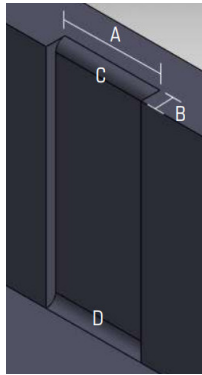

A - 19.67" (500mm) for each 300 points

B - Min. 1.97" (50mm)

C - Rounded lip

D - Rounded base

A rounded lip must be formed on the recess's upper edge and base, to provide gentle paths to guide the fibers and never through forced sharp 90° angles.



### 2. Floor marking

#### 2-A Point definition

With a standard construction marking spray paint, mark the points to position the supports for the fibers.



#### 2-B Cautions

Always leave a minimum gap of 7.87" (200mm) between the walls and floor to prevent unsightly reflections.

### 3. Fiber Supports

Custom formulated with ABS polymer, impervious to mild acids and alkalis, Fiber Supports are fixed to the pool sub-surface with adhesive, are the easiest way to position fibers in floors and walls prior to coating with cement, mortar, concrete or screeds, including self-leveling compounds.

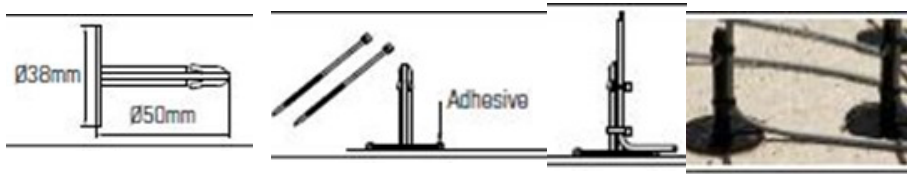

#### 3-A Setting

Place one Fiber Support over each mark, into a bed of building adhesive (SIKA Power-1511 or similar).

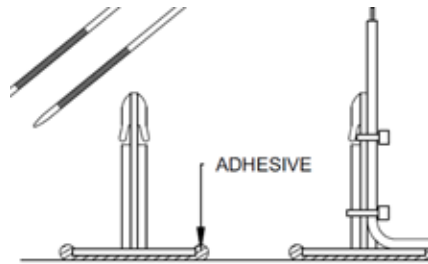

#### 3-B Verticality

The shaft of the Fiber Supports should be vertical, although when installing the same on inclined planes, such as the floors of pools with different depths, a slight inclination will not affect the point performance.

#### 3-C Curing

Although fast epoxy adhesives may surface cure in minutes, we recommend leaving the supports to rest overnight for thorough hardening.

### 4. Fiber installation

#### 4-A Preparation

Unwind the fiber bundle at the illuminator location leaving a minimum of one meter of extra length coiled next to the illuminator (This is the maintenance loop, see section 8 Commissioning. The extra length needed has been contemplated at factory level). Feed the fibers through the pipes / tubes or conduits and roll out to the prepared fiber ingress point and vertical recess on the pool's wall.





#### 4-B Fiber deployment

Spread the fibers across the wall recess and secure to pegs or extra supports to keep in place while applying beads of a fast-curing building adhesive (Fischer MS Ultra Tack, or similar).



#### 4-C Distribution

Distribute the fibers to fasten each onto its designated Fiber Support, all the time tidying the layout with beads of adhesive (Fischer MS Ultra Tack, or similar), to keep the fibers grouped in neat lines. This is critical to ensure that the installers have well-defined open spaces to move across the workplace and avoid damaging the fibers by stepping over them. Care must be taken as Fibers and Fiber Supports are not to be tread on!



#### 4-D Fastening

Secure each fiber to the Fiber Support with two nylon cable ties (2mm x 100mm are recommended), trimming the fibers so they project a minimum of 150mm+ from the tip of the Fiber Support. Adequate excess fiber star point lengths at the tip is critical, as the pool floor will be built up around them, for excess to be trimmed down later.



#### 4-E Testing

Connect the optical port to the illuminator and perform a dry run to ensure that each fiber star point lights up. If any fiber has become damaged during the installation, replace with one of the spare fibers included in each fiber bundle. BL Lighting always includes extra fibers of the longest measurement to use as spares in the event of accidental damage. To obtain a better impression of the work, a night view of the pool floor from above will convey a rough idea of the finished effect.



Another way of testing that all fibers are undamaged and operational is to remove the optical port from the illuminator and check that it is perfectly lit, without dark points. This is particularly effective on a sunny day.

#### 4-F Finishing

Tidy up and check the layout, adding adhesive to ensure that the fibers will not move or interfere with the work of the specialists applying the leveling layer and later tiling. The pool floor ready for the next stages of the installation should have a similar appearance to that of the following images.

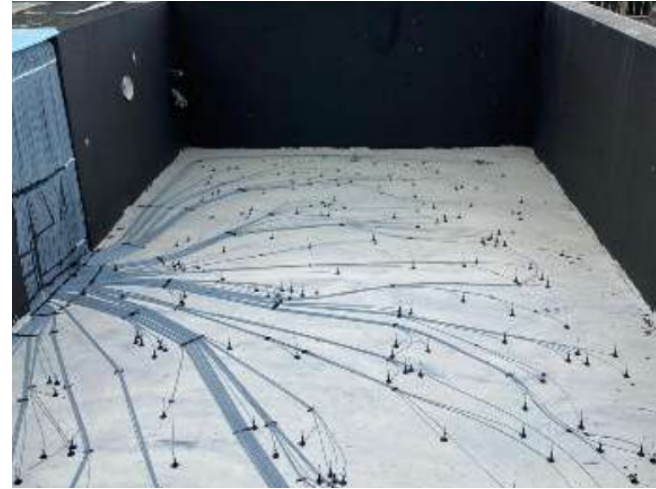

In the wall recess, render over the fibers with sand and cement mortar or the mix specified by the designers, making good to all finishes.



## 5. Leveling layer

### 5-A First layer

Once the fibers are distributed, their ends fastened to the fiber support posts and the layout secured to the concrete floor, a leveling layer of mortar mix or leveling compound (to cover fibers and the base of the supports) will follow. The thickness of the layer will depend on the care with which the fibers are deployed on the concrete base. In general terms, a finished layer of 0.93" to 0.47" (10 to 12mm) will suffice, although we recommend 0.59"(15mm) and, if at all possible, 0.79"(20mm). After a first rough coat to cover the fibers, some installers prefer to remove the tips of the supports and the cable ties before completing the floor with the finishing layer.

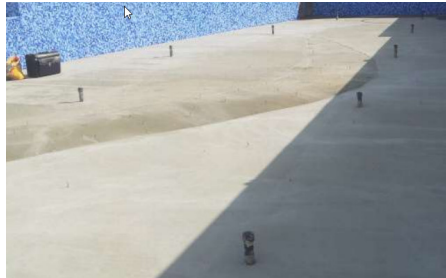

### 5-B Caution

The important issue is to free the fibers at the stage that will suit the technique of the installers. Care must be taken not to step on or damage the fibers.



### 5-C Finishing

After the fibers are roughly covered, apply the finishing layer with the smooth finish required by the installers of the ceramic cladding.



### 5-D Curing

Once this stage is completed, we recommend leaving the pool floor to cure for a period of 24 to 48 hours, dousing with water at intervals to promote hardening of the leveling layer. A floor ready for tiling will seem to have grown "hairs" and great care should be given not to trample over and damage the fibers.

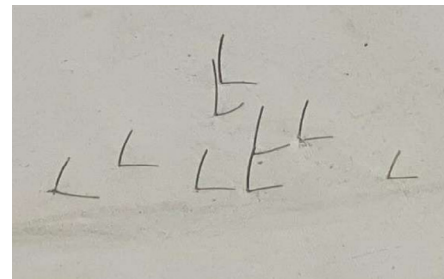
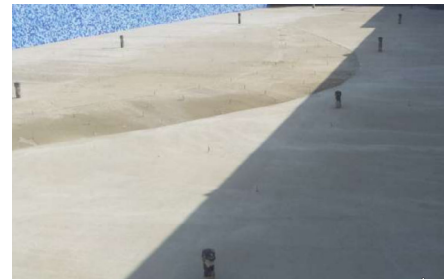



## 6. Tiling and grouting

### 6-A General

For the fibers to surface through the ceramic layer, housings, holes or notches must be cut or drilled into the ceramic pieces. This operation is the most delicate part of the installation and should be executed with care to achieve a perfect finish.

### 6-B Cautions

Although some installers choose to surface the fibers through the joints between ceramic pieces, in particular if those are sizeable and not mosaics, we don't recommend such a practice because regular patterns in the points may destroy the desired starry-sky effect.

### Mosaic ceramics.

#### 6-C Process

The recommended procedure is to commence the installation of the mosaic sheets as usual, remove single tiles where fibers project, and reserve the single mosaic tiles. Once finished tiling, and before grouting, all the removed tiles should be shaped or drilled to provide an opening for the fiber to surface.

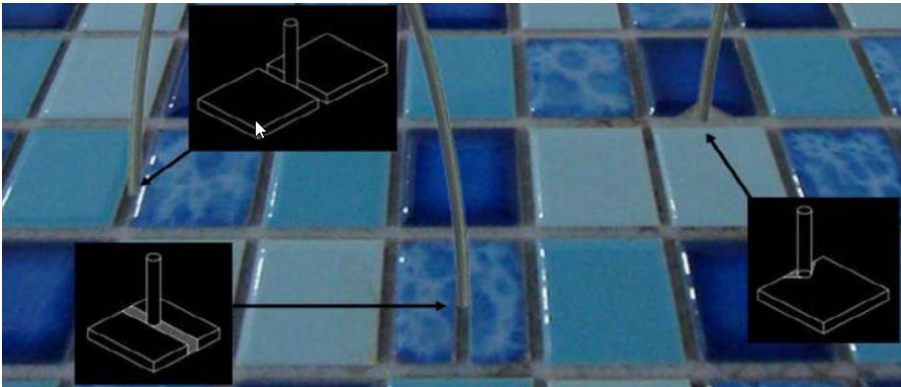

This is a slow process, which should be entrusted to a craftsman. Once finished, all the surfaces should be grouted in the usual way.



### Large format ceramics or natural stones.

#### 6-D Process

In this instance, the fiber location under each ceramic piece must be recorded and transferred to the tile. This operation is better performed with a drill stand equipped with a 0.16" to 0.20" (4 to 5mm) diamond-tipped bit.



The installation of the large ceramic pieces proceeds as usual, followed by the grouting of the joints.

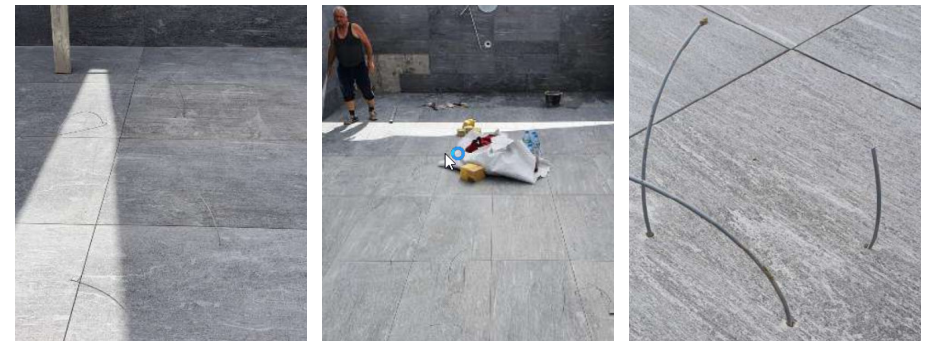

## 7. Trimming

### 7-A Cutting

When the tiled surfaces have been grouted and cleaned, the projecting fibers must be trimmed flush with the floor. To do so, we recommend using flat cutters or pliers of the type used in electronics. No ordinary wire cutters should be used as those will not trim the fibers flush.



### 7-C Finishing

The fibers will now be integrated with the floor, smooth to the touch and invisible during daytime operation.

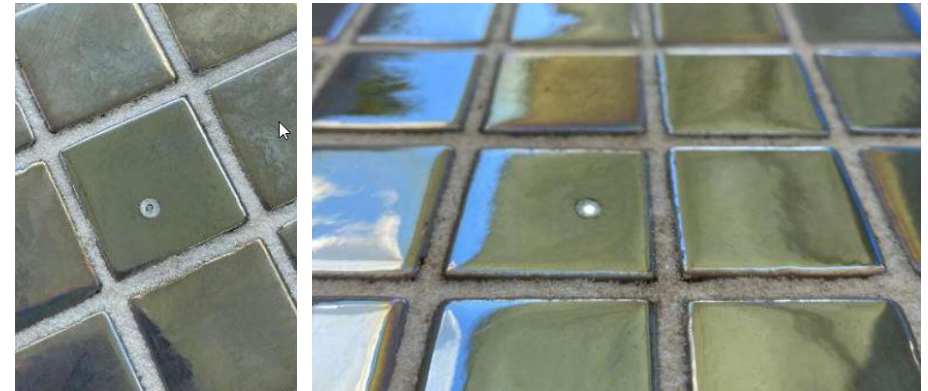

### 7-B Polishing

After trimming, we recommend polishing the fiber ends with a simple felt bob powered by a drill and a dab of polishing compound (MENZERNA B4F, or similar).



## 8. Commissioning

### 8-A Integration with the local system

The installation finished, the illuminator(s) should be secured in its location, connected to the mains power supply and the control lines if the installation is part of a centralized control network. These final operations must be carried out by qualified technicians.

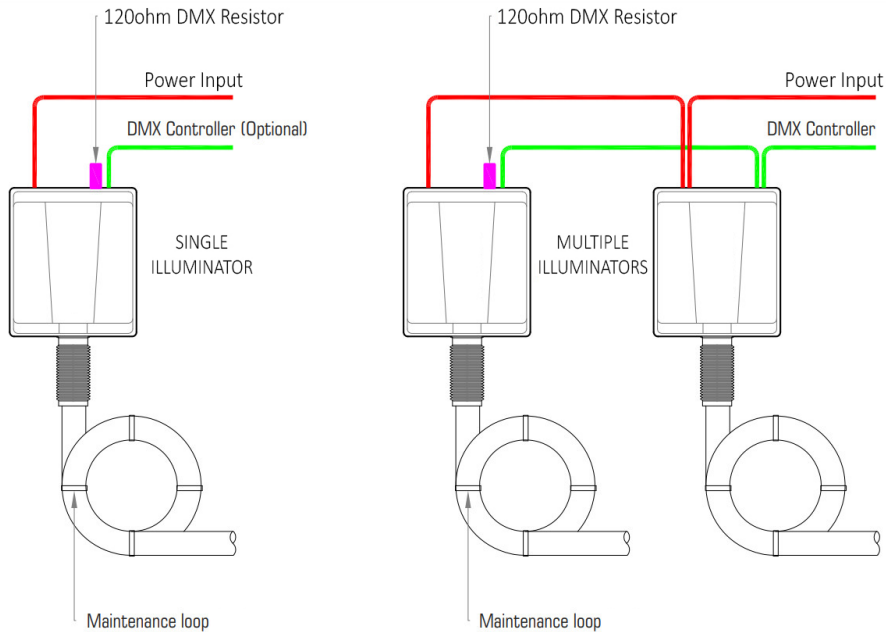

### 8-B Caution

A 120ohm DMX termination resistor must be always installed in DMX-controlled equipment. By closing the in-port, malfunctioning due to extraneous frequency ingress is prevented. Always keep areas of 8" (0.2m) surrounding the BL fiberSOURCE illuminator free, for the unimpaired ventilation of the equipment.